

DOPPIA BARRA QUADRA

NEW MIAMI

Tende a bracci



vedi pag. 7



DIMENSIONI		INCLINAZIONE MIN - MAX	SUPERFICIE MAX COPERTA	TIPOLOGIA BRACCI	TIPOLOGIA SUPPORTO		
LARGHEZZA MAX	SPORGENZA MAX				UNIVERSALE (parete/soffitto)	PARETE	SOFFITTO
1800 cm	600 cm	5° - 70°	111,6	a catena		di serie	optional

COMANDI		DOTAZIONE					
ARGANELLO	MOTORE	MANTOVANA	SUPPORTO INTERMEDIO	FASCIA DI RINFORZO	TENARA	SALDATURA	FRONTALE
a richiesta fino a 1200 cm	meccanico di serie	Tipo 2 - h 25 cm di serie	a rulli di serie	di serie da L > 540 cm	di serie	a richiesta sovrapposta o testa a testa	con drenaggio acqua



NEW MIAMI

DIMENSIONI E INGOMBRI

CARATTERISTICHE TECNICHE

SPORGENZA TENDA MAX

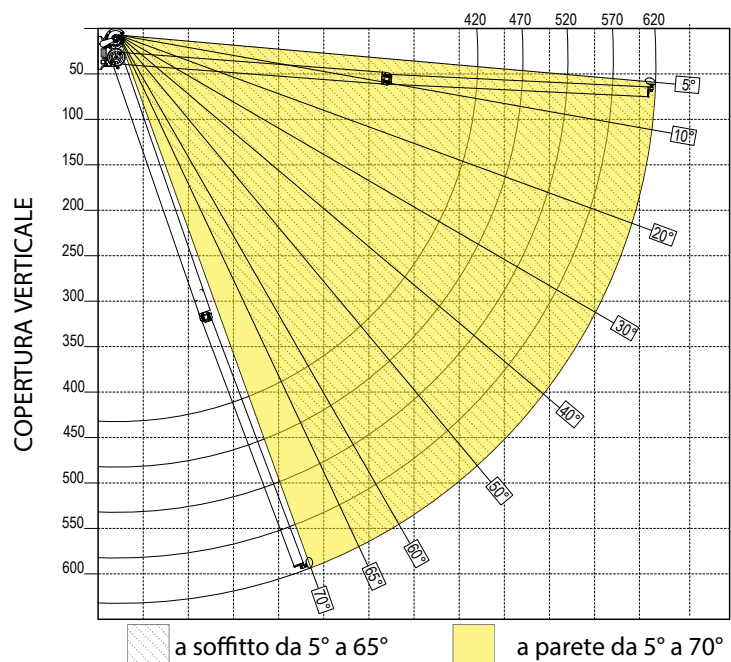

INCLINAZIONE TELO

Supporti Tenda

Supporti a soffitto: in acciaio
Supporti rullo: alluminio pressofuso
Supporti universali: fusione in conchiglia 44100
Supporti parete: fusione in conchiglia 44100
Supporti bracci: fusione in conchiglia 44100

Supporti Bracci

Con regolazione millimetrica dell'inclinazione della tenda e dell'assetto a braccio chiuso.

Supporto Intermedio

Oltre L 5,4 mt - A rulli, con fascia di serie.

Profili

Alluminio estruso lega EN AW-6063.

Barra Quadra

Acciaio alta resistenza, zincata e termolaccata.

Rullo Avvolgitore

Acciaio zincato Ø 78

Bracci Estensibili

Alluminio estruso lega EN AW-6063, fusione in conchiglia 44100.

Viteria

Acciaio INOX AISI 304 - Vite reg. supporto braccio in acciaio altissima resistenza AL12.9 Dacromet.

Finitura

Parti metalliche (esclusa viteria) protette tramite vernicitura a polvere a base di poliesteri (resistente a corrosione / meccanica / UV).
Particolari in alluminio protetti tramite fosfocromatazione e termolaccatura con polvere a base di poliesteri.
Coperture dei componenti principali in Nylon 6.6 trattati con esclusivo sistema superficiale anti UV.

Per inclinazione minima vedi:



AVVERTENZE

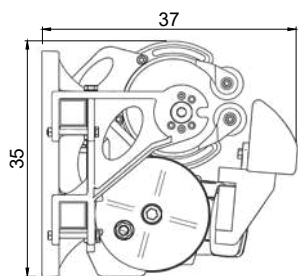

(misure in cm)

ATTACCO PARETE

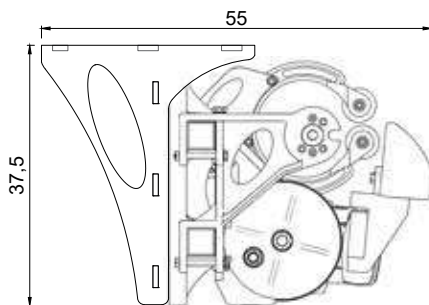

(misure in cm)

ATTACCO SOFFITTO

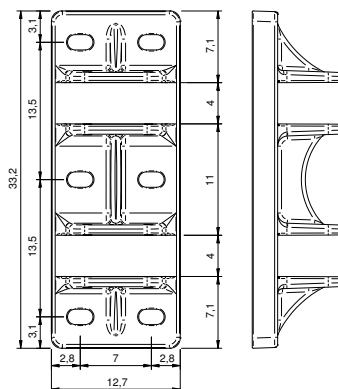

(misure in cm)

SUPPORTO PARETE
(di serie)

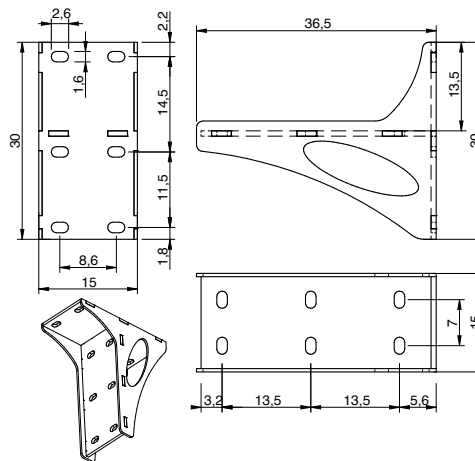

(misure in cm)

SUPPORTO SOFFITTO
(optional)

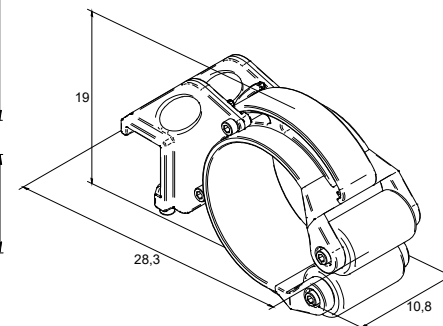

(misure in cm)

SUPPORTO INTERMEDIO A RULLI